

Disclaimer: This packet is intended ONLY for the use of students enrolled in Leon County Schools.

This document provides a breakdown of activities per week. Please check off the pages as they are completed.

Kindergarten

Week 1:

- | | | |
|--------------------------|-------------|--------------|
| <input type="checkbox"/> | Pages 39-40 | MAFS.K.G.1.1 |
| <input type="checkbox"/> | Pages 41-42 | MAFS.K.G.1.2 |

Week 2:

- | | | |
|--------------------------|-------------|------------------------|
| <input type="checkbox"/> | Pages 31-32 | MAFS.K.MD.1.1 |
| <input type="checkbox"/> | Page 68 | Mixed Standards Review |

Week 3:

- | | | |
|--------------------------|---------|------------------------|
| <input type="checkbox"/> | Page 61 | Mixed Standards Review |
| <input type="checkbox"/> | Page 63 | Mixed Standards Review |

Week 4:

- | | | |
|--------------------------|-----------------|------------------------|
| <input type="checkbox"/> | Pages 65-66 | Mixed Standards Review |
| <input type="checkbox"/> | Pages 55 and 63 | Mixed Standards Review |



MATH

WEEK 1

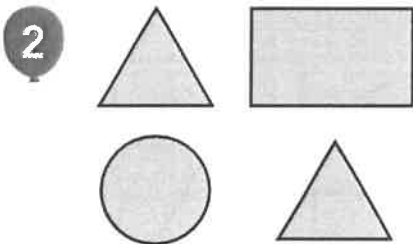

- The turtle is above the apple.
- The heart is next to the dog.
- The bird is below the heart.

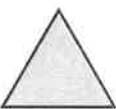

- 
- 
- 

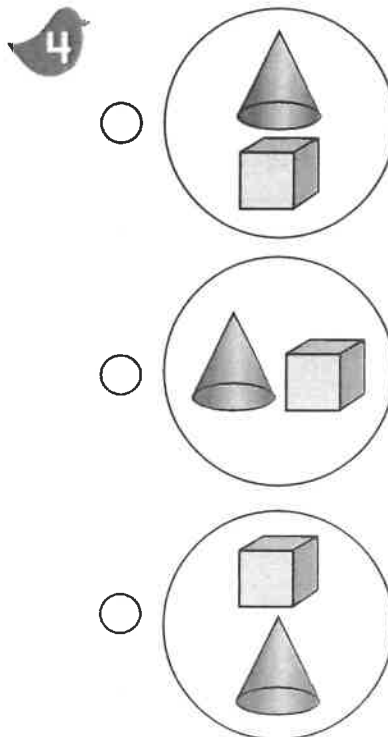
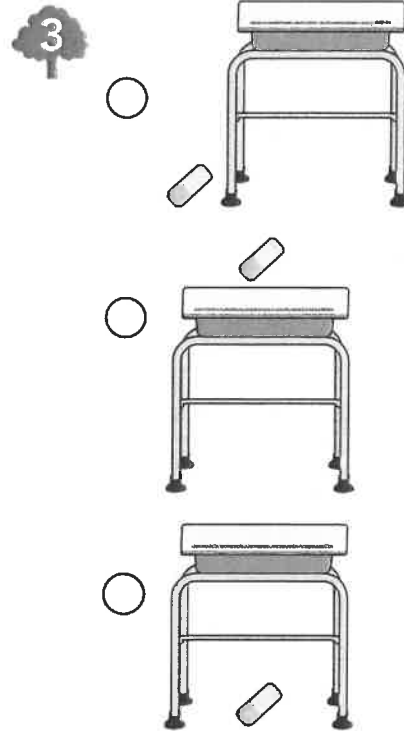

Directions:

1. Which is true about the picture? 2. Which shape is above the triangle? 3. Which picture shows an eraser under a desk? 4. Which picture shows a cone above a cube?

5



- A cylinder is beside a sphere.
- A cylinder is under a sphere.
- A cylinder is above a sphere.

6

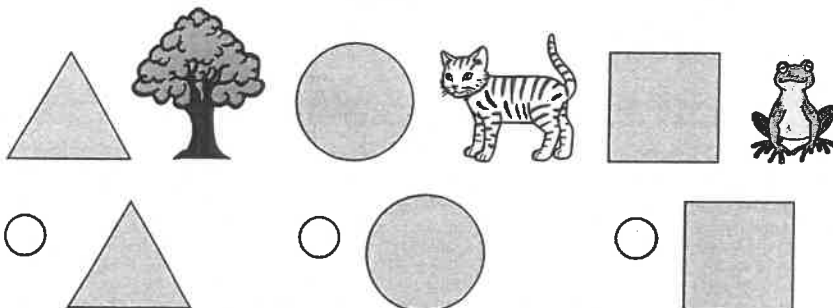

7

A cone is beside a sphere.



A cone is above a cube.

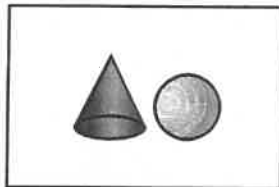

A cube is below a cylinder.

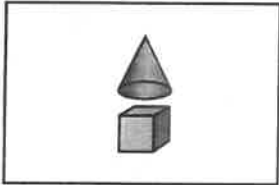

8

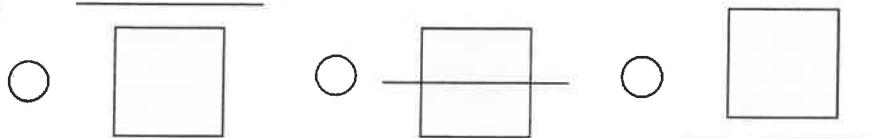

Directions:

5. Damon draws these shapes. Which sentence is true about Damon's shapes? 6. Which shape is next to both the tree and the kitten? 7. Which sentence tells about each picture? Draw a line from each picture to the correct sentence. You will use all the pictures. 8. Which picture shows a square below a line?

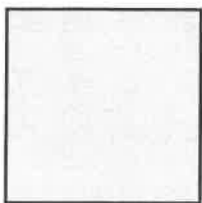

- circle
- square
- triangle

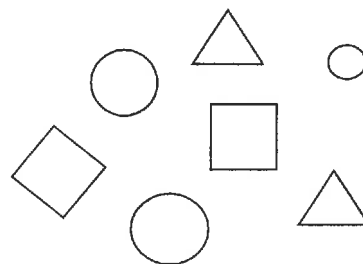
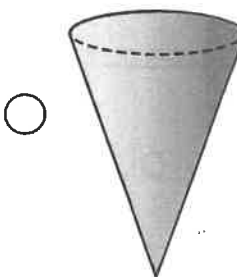
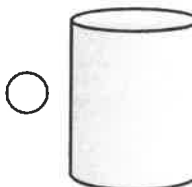
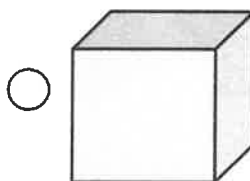
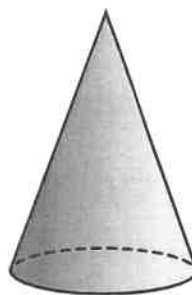
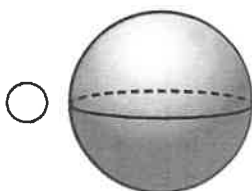
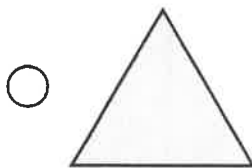
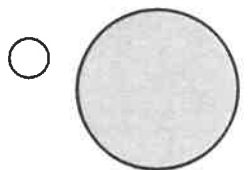

Directions:

1. What is the name of the shape? 2. Which shows a sphere? 3. Mike sees this shape. Which other shape is the same kind as Mike's? 4. Circle all the squares.

5

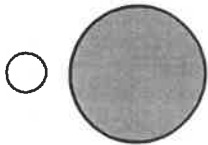
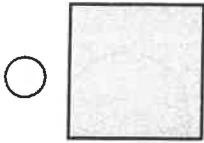

6

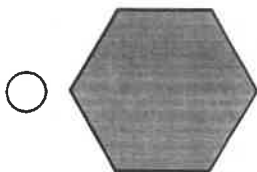
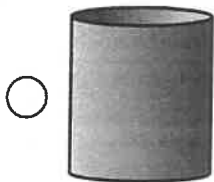
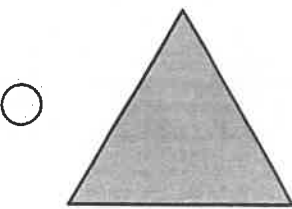

7

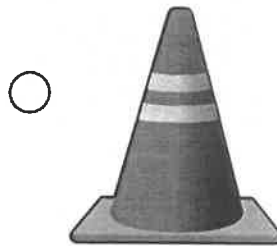
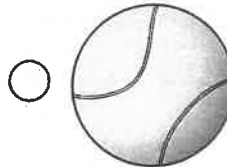
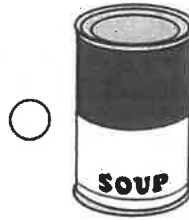

8

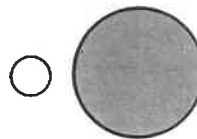
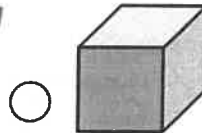

Directions:

5. Which shows a circle? 6. Which shape is a hexagon? 7. Which picture is shaped like a sphere? 8. Which shows a picture of a cylinder?

Kindergarten Week 1

Dear Parent/Guardian,

During Week 1, your child will review a variety of skills, including letter and sound /o/, blending words emphasizing the /p/, /t/, /m/, /n/, /o/ sounds, practicing handwriting, using adjectives to complete sentences and demonstrate comprehension using decodable passages.

We also suggest that students have an experience with reading each day. Reading at home will make a HUGE difference in your child's school success! Make reading part of your everyday routine. Choose books that match your child's interests. Reading for 20 minutes a day will continue to grow your young reader's vocabulary and comprehension.

Links for additional resources to support students at home are listed below for letters and numbers review, sight word practice, colors, shapes, and more:

<https://classroommagazines.scholastic.com/support/learnathome.html>

<https://www.education.com/>

<http://www.sheppardsoftware.com/>

<https://www.funbrain.com/>

<https://www.starfall.com/h/>

<https://www.abcya.com/>

Week 1 At A Glance	
Day 1	<input type="checkbox"/> Read for 20 minutes <input type="checkbox"/> Sound /o/ Page 102
Day 2	<input type="checkbox"/> Read for 20 minutes <input type="checkbox"/> Blending -ot, -on, -op Page 104
Day 3	<input type="checkbox"/> Read for 20 minutes <input type="checkbox"/> Trace and Write Oo Page 26
Day 4	<input type="checkbox"/> Read for 20 minutes <input type="checkbox"/> Adjectives in Sentences Page 30
Day 5	<input type="checkbox"/> Read for 20 minutes <input type="checkbox"/> Decodable Passage Page 4



Name _____

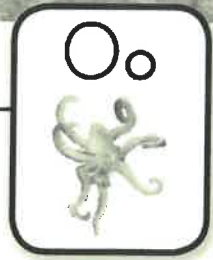

1.

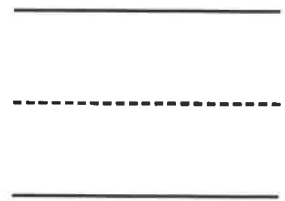
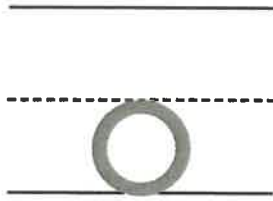
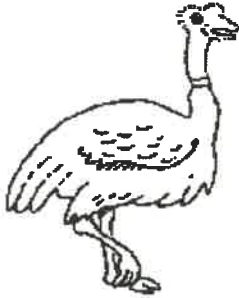

2.

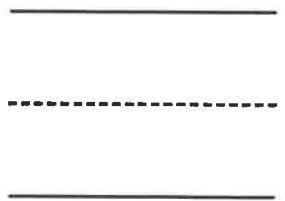
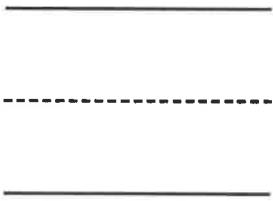
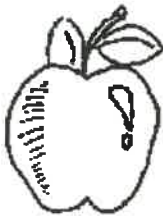

3.

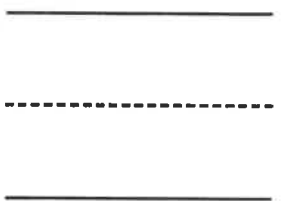
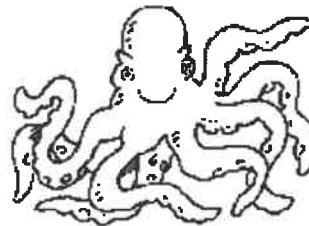
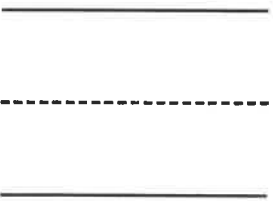

4.

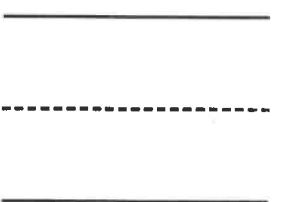
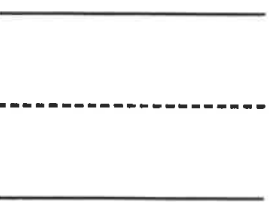
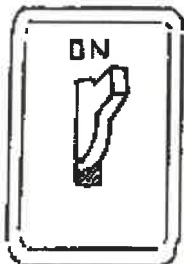

Copyright © The McGraw-Hill Companies, Inc.

Beginner/Intermediate

Phonics: /o/o Point to and say *ostrich* emphasizing /o/. Have children repeat. Guide them to write o next to the *ostrich*. Have children write o next to each picture whose name begins with /o/. Ask them to tell the picture names beginning with o to a partner. Then display **Word-Building Card o** and use **Photo Cards** beginning with letter o to reinforce /o/o.



Name _____

pot on mop

1.

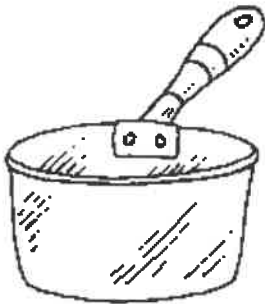

pot

pot

2.

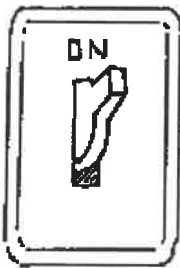

on

3.

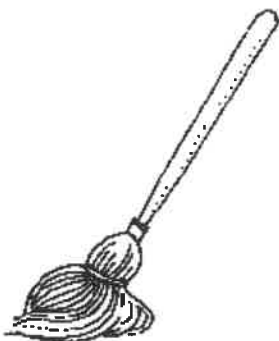

mop

Copyright © The McGraw-Hill Companies, Inc.

Beginner/Intermediate

Phonics: Blending -ot, -on, -op Point to *p* in the word *pot* and say /p/. Repeat for letters *o* and *t*. Blend the sounds and say the word. Have children repeat. Then guide them to write the word and read it to a partner. Repeat routine for *on* and *mop*.

Name _____

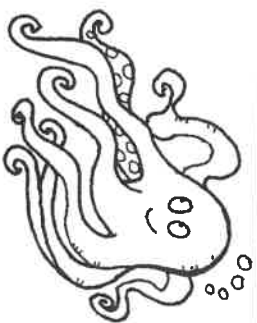
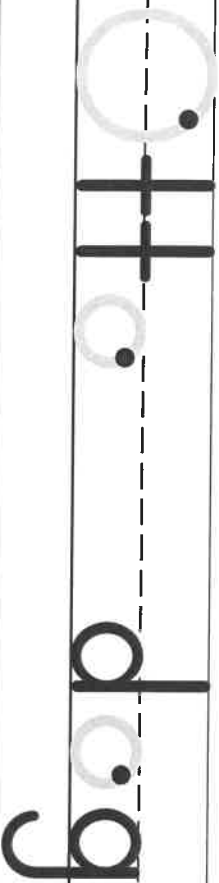
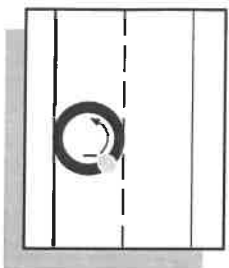
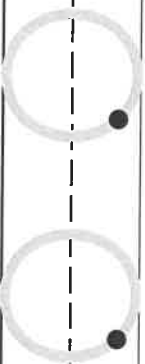
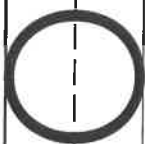
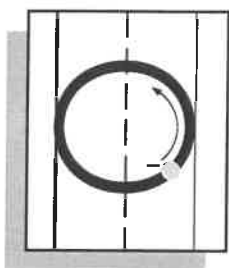

Name _____



round tall blue



1. I sit under a _____
_____ tree.

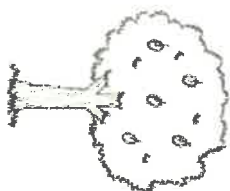

2. I see the _____
_____ sky.

3. The _____
_____ sun shines on me.



Adjectives Listen to each sentence. Write an adjective from the word box in each sentence.



Name _____

Mom and Pop Mop

1. Pop can mop.
2. Mom can mop.
3. Mom and Pop can mop.

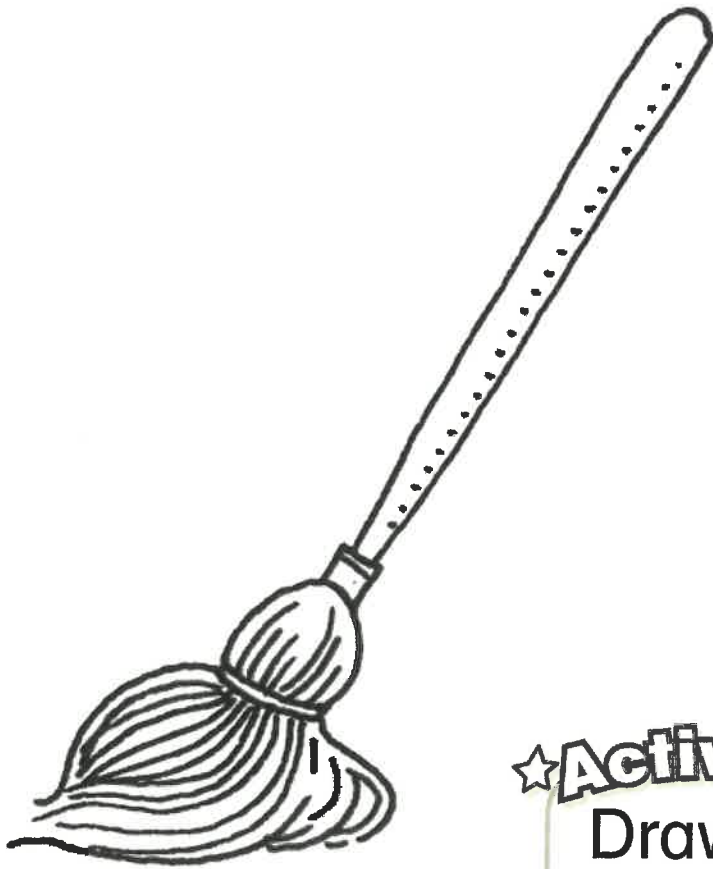

★Activity★

Draw what Mom
and Pop can do.

Disclaimer: This packet is intended ONLY for the use of students enrolled in Leon County Schools.

This document provides a breakdown of activities per week. Please check off the pages as they are completed.

Kindergarten

Week 1:

- Five Senses Book
- Five Senses Worksheet

Week 2:

- Reptiles Earth Science Worksheet
- Life Science Student Worksheet

Week 3:

- Plants are yummy! Worksheet
- Five Senses Worksheet for Kids

Week 4:

- Me and My Shadow by: ReadWorks

Week

1

senses



We use our five senses to explore the world.

My Itsy Bitsy Five Senses Book

Name: _____

sight

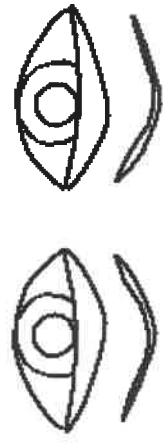

We use our eyes to see.

KidZone.ws
Itsy Bitsy Books

Free printables from:
<http://www.kidzone.ws>

taste



We use our mouth to taste.

We use our skin to touch.



touch

smell



We use our nose to smell.

We use our ears to hear.



hearing



Five Senses Worksheet

Name _____

Draw a line that matches each sense with the correct image.

sight



smell

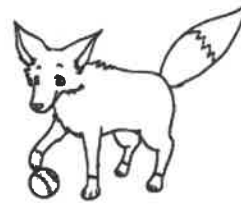

touch



hearing



taste



NAME _____

SCHOOL _____

Disclaimer: This packet is intended ONLY for the use of students enrolled in Leon County Schools.

Grade K
Geography
Multicultural/ Women's History Reading

Standards:

SS.K.G.1.1 Describe the relative location of people, places, and things by using positional words.

SS.K.G.1.2 Explain that maps and globes help to locate different places and that globes are a model of the Earth.

SS.K.G.1.3 Identify cardinal directions (north, south, east, west).

SS.K.G.1.4 Differentiate land and water features on simple maps and globes.

Florida Statutes (1003.42):

(h) The history of African Americans, including the history of African peoples before the political conflicts that led to the development of slavery, the passage to America, the enslavement experience, abolition, and the contributions of African Americans to society. Instructional materials shall include the contributions of African Americans to American society.

(q) The study of women's contributions to the United States.

Resources:
education.com
ReadWorks.org
Superteachersworksheet.com

Position and Direction

Look at the illustration on the right.
Then circle the correct answers below.

1. The stars are (**around** / **within**) the circle.
2. The X is (**outside** / **inside**) the square.
3. The arrow is on the (**left** / **right**) of the triangle.
4. The arrow is pointing (**south** / **east**).
5. The oval is (**around** / **within**) the circle.
6. The S is on the (**left** / **right**) side of the rectangle.
7. The Z is (**north** / **south**) of the rectangle.
8. The star with a black dot is (**west** / **east**) of the oval.
9. The triangle is (**below** / **above**) the rectangle.
10. The P is to the (**left** / **right**) of the arrow.

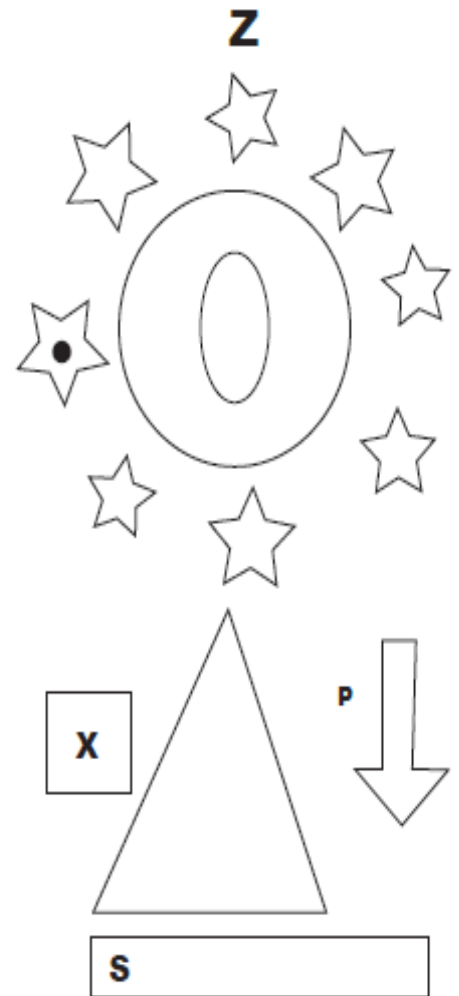

Reading a Map

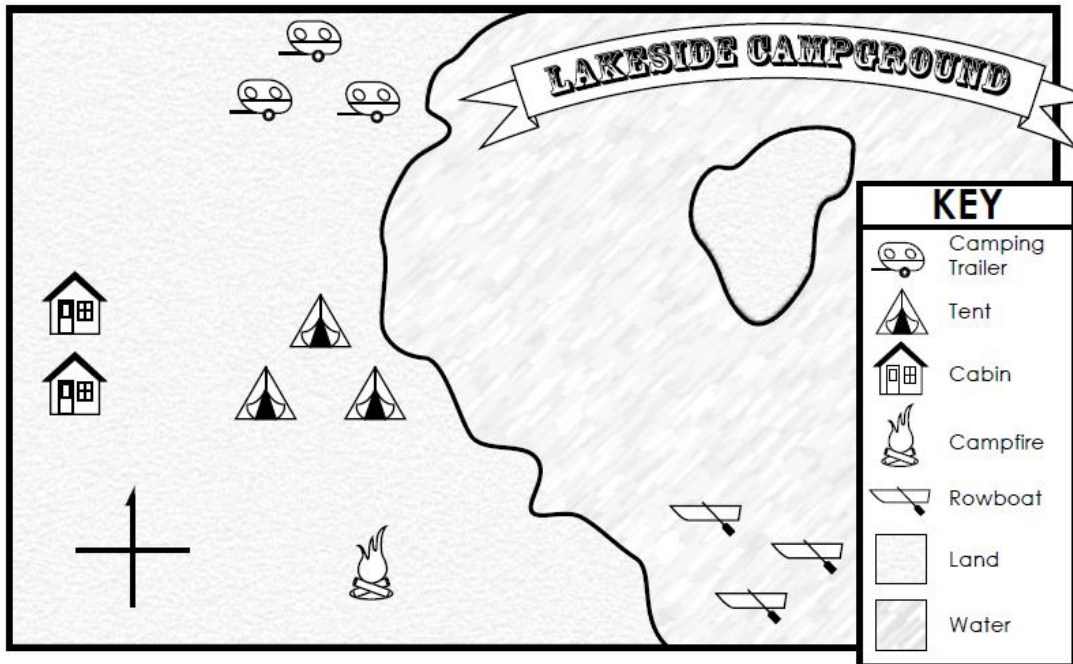

1. Label **N**, **S**, **E**, and **W** on the compass rose.
2. Color the land **green** and the water **blue**.

Write **north**, **south**, **east**, or **west** to complete each sentence.

3. The rowboats are _____ of the campfire.
4. The camping trailers are _____ of the tents.
5. The cabins are _____ of the tents.
6. The campfire is _____ of the camping trailers.
7. The island is _____ of the cabins.

Maps and Globes

Imagine you are on a camping trip with your family. You need to find the place where you are going to camp. You're in the mountains and phones don't work there. What might you use to find your way?

You might use a map! Maps are pictures of a place on Earth. These pictures are printed or drawn on something flat, like a big piece of paper. Maps can help you find your way. Different maps can show you different things. Some maps may show you the roads and rivers near a mountain. Some maps may show you where different towns and cities are. Other maps may even show you where different countries and oceans are!

If you're in your classroom, look around. Do you see a globe? A globe is a round ball with a map of Earth on it. You can find the Earth's oceans on a globe. You can find the Earth's countries on a globe.

Now take a look at these two photos. Which one shows a map? Which one shows a globe?

NAME _____

SCHOOL _____

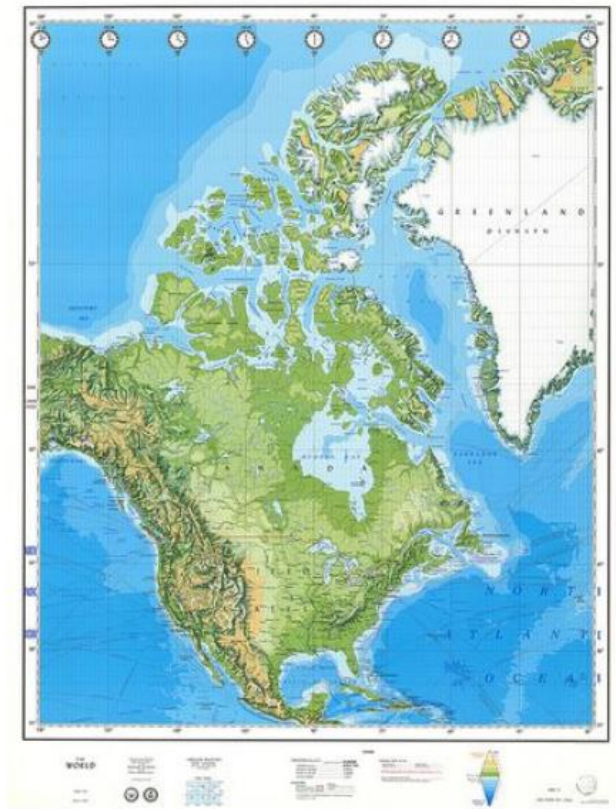

Name: _____ Date: _____

1. What can help you find your way around a mountain?

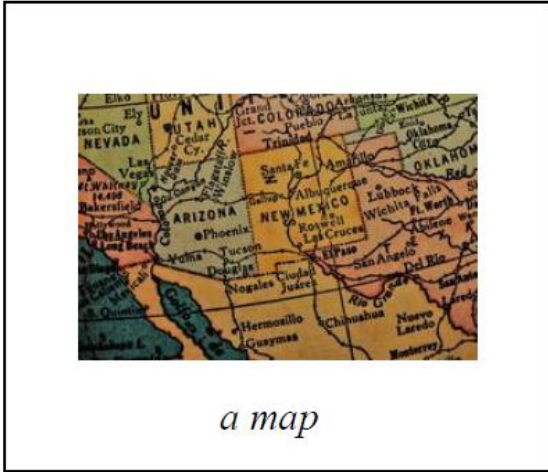

2. What is a map drawn on?

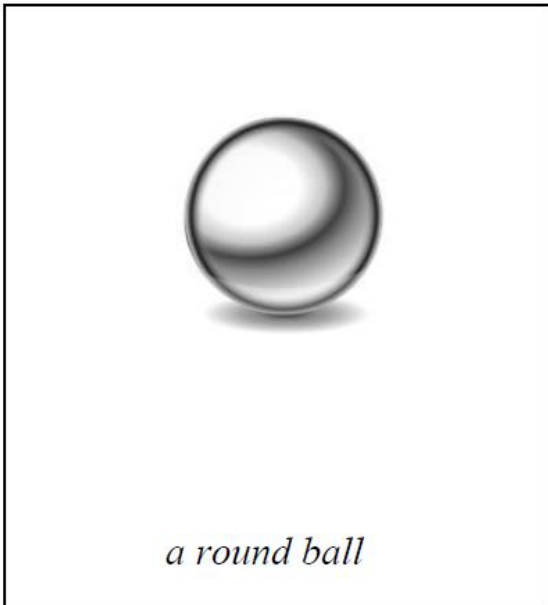
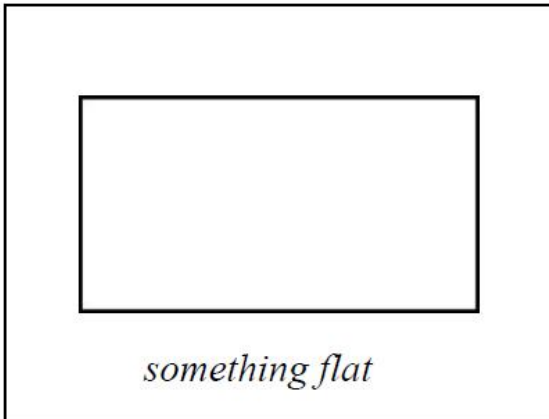

3. What is a globe a map of?



the entire Earth



roads and rivers

4. What shape is a globe?



a flat rectangle



a round ball

NAME _____

SCHOOL _____

ReadWorks®

Maps and Globes - Comprehension Questions

5. What can maps show you?

Maps may show you _____.

6. What did you learn from "Maps and Globes"?

7. Draw a picture of a map.

Women's History Month

by ReadWorks

March is Women's History Month. It is a time for thinking about women who have made a big difference in the world. Some of these women lived hundreds of years ago. Some of them are alive today.

One woman who made a big difference is Harriet Tubman. She was born in the United States around 1820. She was a slave. After she grew up, she ran away. Now she was free!



Harriet Tubman

The next year she came back to help her sister escape. She came back again and again. Each time she helped more slaves escape.

The United States decided to honor women like Harriet Tubman in 1981. That was when Women's History Week began. Six years later, it became Women's History Month.

NAME _____

SCHOOL _____

ReadWorks®

Women's History Month - Comprehension Questions

Name: _____ Date: _____

1. When is Women's History Month?

- A. March
- B. April

2. Women's History Month is a time to think about

- A. women
- B. fathers

3. Harriet Tubman helped

- A. slaves
- B. slave owners

4. When did Women's History Week begin?

- A. 1981
- B. 1820

NAME _____

SCHOOL _____

ReadWorks®

Women's History Month - Comprehension Questions

5. Which picture shows someone who is celebrated during Women's History Month?



Abraham Lincoln



Harriet Tubman

Disclaimer: This packet is intended ONLY for the use of students enrolled in Leon County Schools.

This document provides a breakdown of activities per week. Please check off the pages as they are completed.

Kindergarten

Week 1:	
<input type="checkbox"/> Pages 39-40	MAFS.K.G.1.1
<input type="checkbox"/> Pages 41-42	MAFS.K.G.1.2

Week 2:	
<input type="checkbox"/> Pages 31-32	MAFS.K.MD.1.1
<input type="checkbox"/> Page 68	Mixed Standards Review

Week 3:	
<input type="checkbox"/> Page 61	Mixed Standards Review
<input type="checkbox"/> Page 63	Mixed Standards Review

Week 4:	
<input type="checkbox"/> Pages 65-66	Mixed Standards Review
<input type="checkbox"/> Pages 55 and 63	Mixed Standards Review

MATH

WEEK 2

1

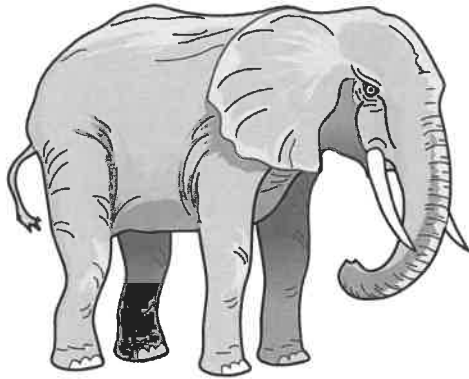

- tall
- light
- short

2

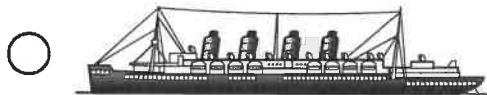

3

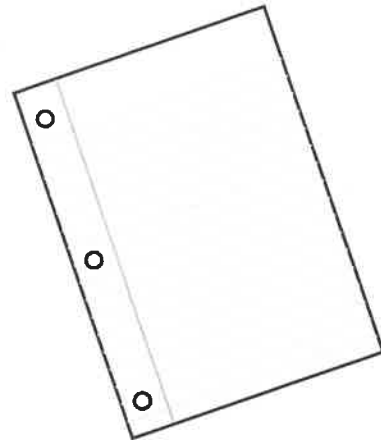

- tall
- light
- heavy

4



- tall
- light
- short

Directions:

1. Which word tells about the elephant? 2. Which picture shows an object that is short? 3. Look at the paper. Which word best tells about the paper? 4. Which word tells about the ladder?

23

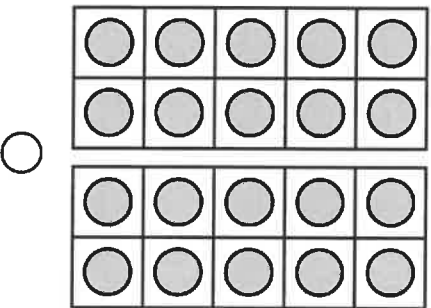
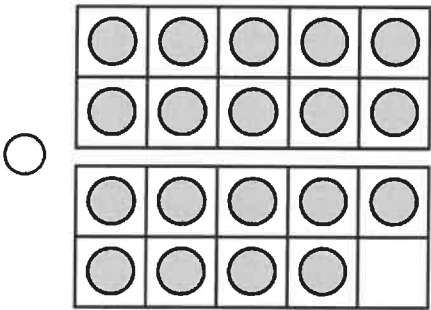
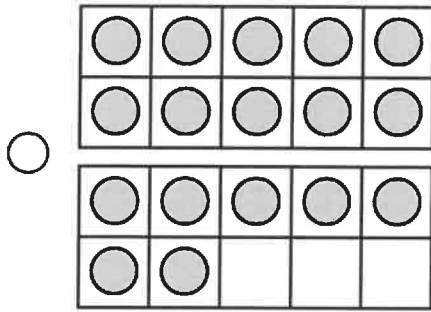

24

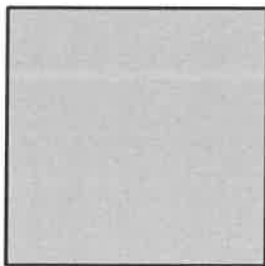

- 6 4 3

25

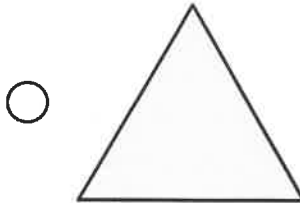
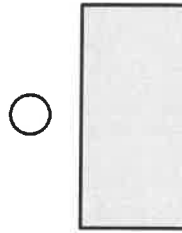
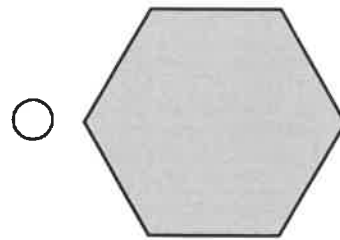

Directions:

23. Which group shows 19? 24. How many sides does this shape have? 25. Which shows a hexagon?

Kindergarten Week 2

Dear Parent/Guardian,

During Week 2, your child will review a variety of skills, including letter and sound /d/, blending words emphasizing the /d/, /t/, /s/, /a/, /o/ sounds, practicing handwriting, using adjectives to complete sentences and demonstrate comprehension using decodable passages.

We also suggest that students have an experience with reading each day. Reading at home will make a HUGE difference in your child's school success! Make reading part of your everyday routine. Choose books that match your child's interests. Reading for 20 minutes a day will continue to grow your young reader's vocabulary and comprehension.

Links for additional resources to support students at home are listed below for letters and numbers review, sight word practice, colors, shapes, and more:

<https://classroommagazines.scholastic.com/support/learnathome.html>

<https://www.education.com/>

<http://www.sheppardsoftware.com/>

<https://www.funbrain.com/>

<https://www.starfall.com/h/>

<https://www.abcya.com/>

Week 2 At A Glance	
Day 1	<input type="checkbox"/> Read for 20 minutes <input type="checkbox"/> Sound /d/ Page 110
Day 2	<input type="checkbox"/> Read for 20 minutes <input type="checkbox"/> Blending /d/ Page 112
Day 3	<input type="checkbox"/> Read for 20 minutes <input type="checkbox"/> Trace and Write Dd Page 28
Day 4	<input type="checkbox"/> Read for 20 minutes <input type="checkbox"/> Adjectives in Sentences Page 32
Day 5	<input type="checkbox"/> Read for 20 minutes <input type="checkbox"/> Decodable Passage Page 5



Name _____



1.

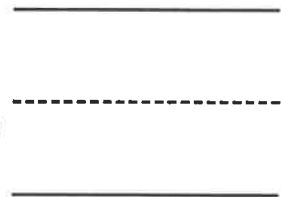
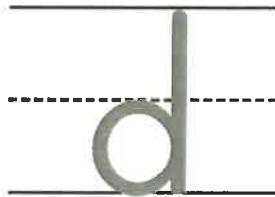
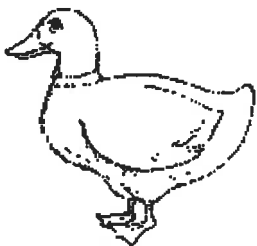

2.

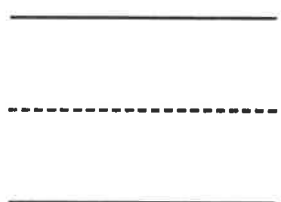
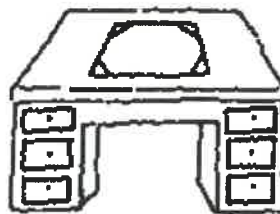
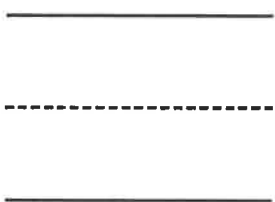

3.

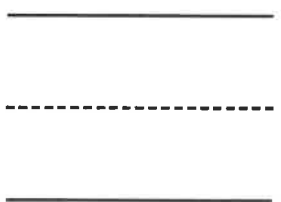
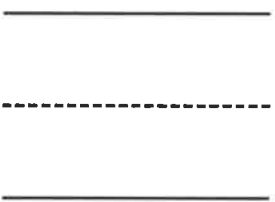

4.

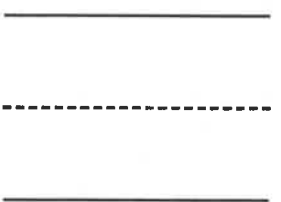
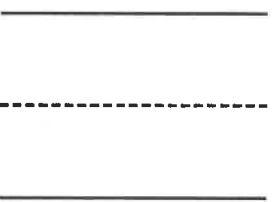
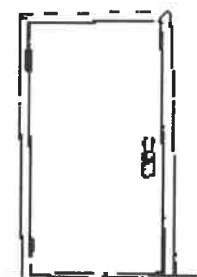

Copyright © The McGraw-Hill Companies, Inc.

Beginner/Intermediate

Phonics: /d/d Point to and say *duck* emphasizing /d/. Have children repeat. Guide them to write *d* next to the *duck*. Have children write *d* next to each picture whose name begins with /d/. Ask them to tell the picture names beginning with *d* to a partner. Then display **Word-Building Card d** and use **Photo Cards** beginning with letter *d* to reinforce /d/d.



Name _____

Dan dot sad

1.



Dan

Dan

2.



dot

3.



sad

Beginner/Intermediate

Phonics: Blending /d/ d Point to *D* in the word *Dan* and say /d/. Repeat for *a* and *n*. Blend the sounds and say the word. Have children repeat. Guide children to write the word and read it to a partner. Repeat routine for *dot* and *sad*.

Name _____

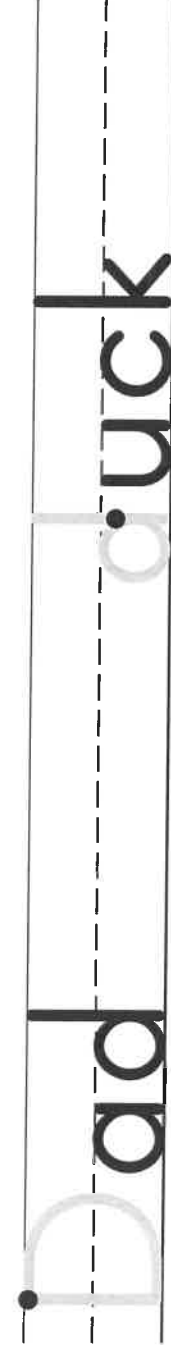
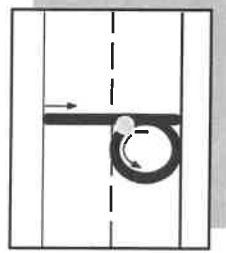
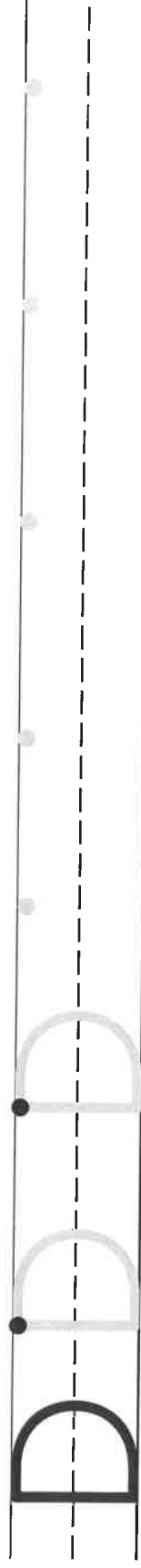
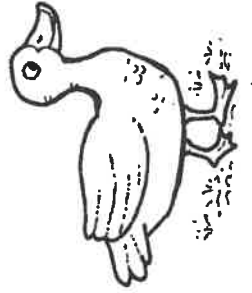
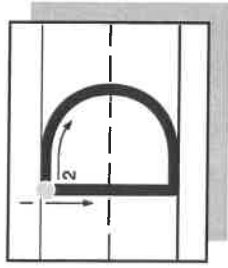

© Macmillan/McGraw-Hill

Directions: Duck starts with the letter **D**. Point to the capital **D** and trace it. Trace and write all the capital **D**'s. Point to the small **d** and trace it. Then trace and write all the small **d**'s.

Name _____



big soft tiny

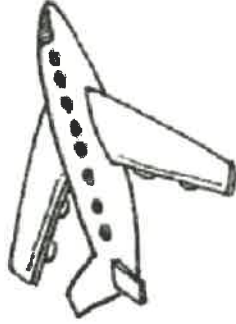

1. A jet is _____.

2. Jack sees a _____ ant.

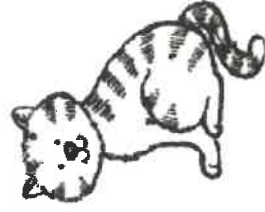

3. My kitten's fur is _____.

Adjectives Listen to the three words and the sentence. Write an adjective from the word box in each sentence.

Name _____

Don

1. Don can see Ted.
2. Ted can see Don.
3. Don and Ted can go.
4. Don and Ted sit and nap!



★Activity★

Draw what Don
can do.

Disclaimer: This packet is intended ONLY for the use of students enrolled in Leon County Schools.

This document provides a breakdown of activities per week. Please check off the pages as they are completed.

Kindergarten

Week 1:

- Five Senses Book
- Five Senses Worksheet

Week 2:

- Reptiles Earth Science Worksheet
- Life Science Student Worksheet

Week 3:

- Plants are yummy! Worksheet
- Five Senses Worksheet for Kids

Week 4:

- Me and My Shadow by: ReadWorks

Week

2



Earth Science Worksheet

Reptiles

Name _____

Circle the pictures of reptiles.

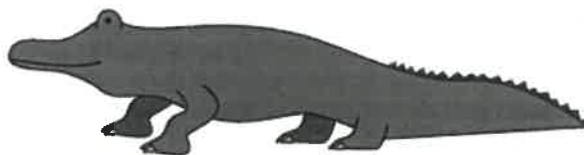
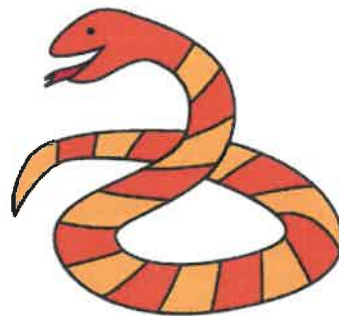
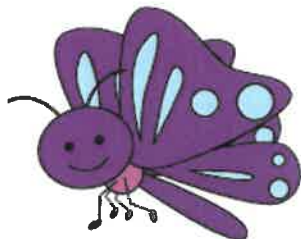
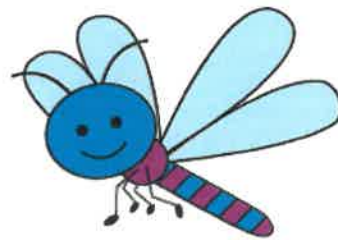
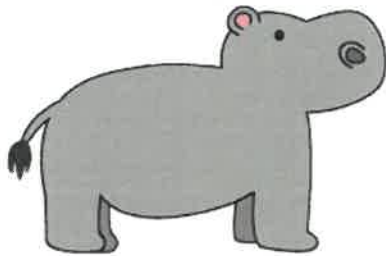



Life Science Student Worksheet

Name _____

Circle the pictures that are living things.

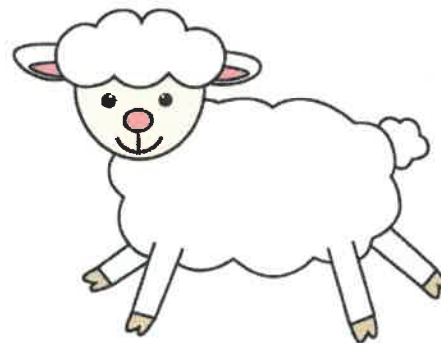
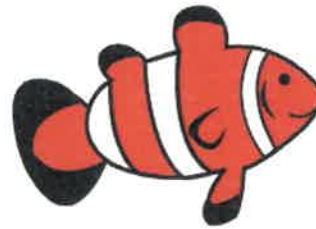
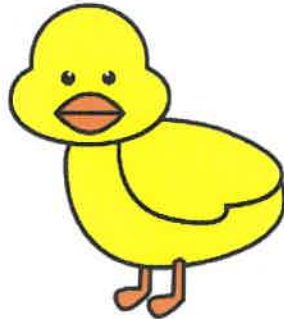

NAME _____

SCHOOL _____

Disclaimer: This packet is intended ONLY for the use of students enrolled in Leon County Schools.

WEEK 2

Grade K

Civics and Government Women's History Reading

Standards:

SS.K.C.2.1 Demonstrate the characteristics of being a good citizen.

SS.K.C.2.2 Demonstrate that conflicts among friends can be resolved in ways that are consistent with being a good citizen.

SS.K.C.2.3 Describe fair ways for groups to make decisions.

Florida Statutes (1003.42):

(q) The study of women's contributions to the United States.

Resources:
ReadWorks.org

Vocabulary

- **citizen**- a person who is part of a community

Directions: Circle the words that demonstrate good citizenship.

1. share take
2. hurt help
3. mean nice
4. listen ignore
5. fair unfair
6. honest lie
7. polite rude

NAME _____

SCHOOL _____

Solving a Conflict

A **conflict** is when people disagree.

Directions: Draw a picture that demonstrates how a good citizen would resolve the following conflict.

Someone wants to play with the same toy you are playing with.

Directions: Write a sentence that explains how you resolved the conflict.

Who Is a Good Citizen at School?

by ReadWorks



Good citizens at school help other people. They follow the class rules.

Good citizens do their school jobs. They talk nicely to one another. They do their best to answer the teacher's questions. They work together with other students.

Good citizens are kind. They do not make fun of others. Are you a good citizen at school?

Name: _____ Date: _____

1. What do good citizens at school do?



They always yell and dance.



They follow the class rules.

2. How do good citizens talk to one another?

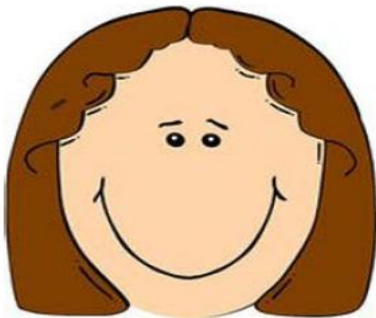

nicely

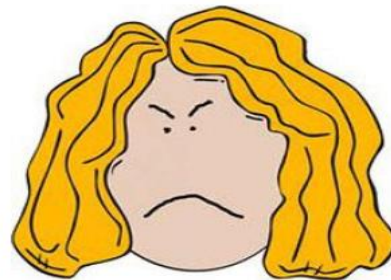

angrily

ReadWorks®

Who Is a Good Citizen at School? - Comprehension Questions

3. What kind of student does his or her best to answer the teacher's questions?



a troublemaker



a good citizen

ReadWorks®

Who Is a Good Citizen at School? - Comprehension Questions

4. How do good citizens treat others?



They make fun of others.



They help others and are kind.

NAME _____

SCHOOL _____

5. How do good citizens work with other students?

They work

Sybil's Brave Ride

by ReadWorks



Sybil Ludington lived long ago. When Sybil was 16, America was fighting with England.

One night, the English army was coming. Sybil wanted to warn the American people. She was brave. She rode all night on her horse. It was rainy and cold.

She told people about the army. Thanks to Sybil, the people were ready. They were able to protect their country.

Name: _____ Date: _____

1. When did Sybil Ludington live?



2. Which country was America fighting when Sybil was 16?

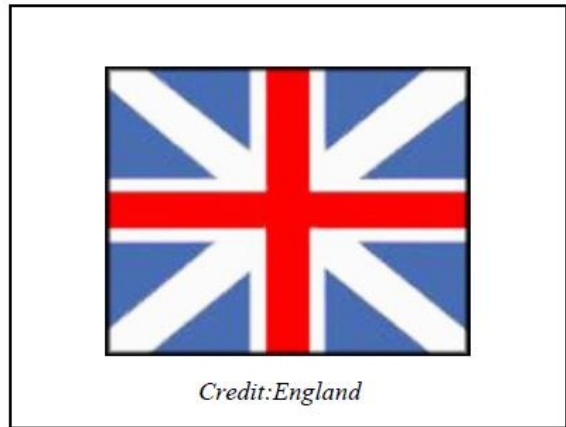

ReadWorks®

3. What did Sybil see coming one night that she wanted to warn people about?



the English Army



a hurricane

4. What could the American people do thanks to Sybil Ludington?



protect their country



run away

NAME _____

SCHOOL _____

ReadWorks®

Sybil's Brave Ride - Comprehension Questions

5. What animal did Sybil ride to warn people about the army?

Sybil rode

6. What did you learn from "Sybil's Brave Ride"?

7. Draw a picture of Sybil warning people about the English army.